

STENOGRAPH

Online Monitoring the Density Distribution
with the Density Analyser



GreCon®

Influence the Features of Wood Based Panels with the GreCon Raw Density Measuring System

For MDF, particleboard and OSB boards, the raw density has a decisive influence on the panel quality. For the economic production of wood based panels, this parameter is one of the most important that needs to be monitored and optimised. Depending on the end use of the wood based panel, different density profiles are required. Continuous online monitoring is necessary in order to ensure optimum adjustment of the production line. Using the Raw Density Profile Analyser StenOgraph allows operators to adjust the production process to maximum efficiency.

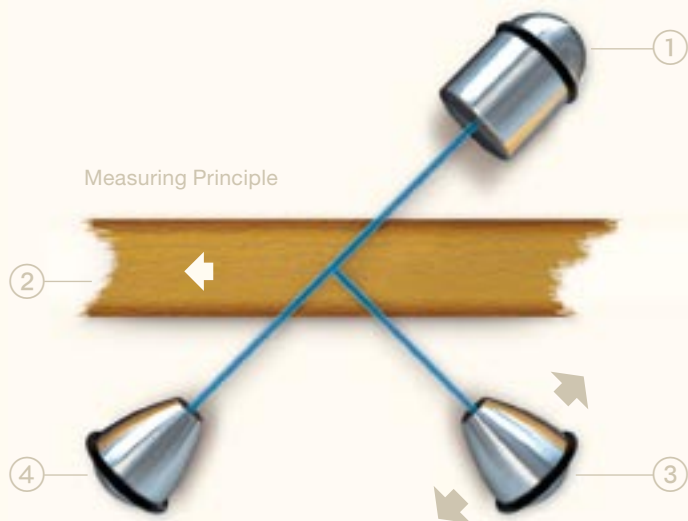

Increasing the Productivity

Due to non-optimal raw density profiles, wood based panels are often manufactured with an elevated raw density. Our clients informed us that by using the StenOgraph they were able to reduce the average raw density by 2.5 % or more.

When switching from one product type to another, a certain „running-in“ time is necessary for new product parameters. With the StenOgraph the specified parameters are achieved within a much shorter period of time. In a typical MDF production plant, the costs of substandard products from product switch over were reduced by 33 % using the StenOgraph system.

Minimising the specific press time while increasing the capacity by approximately 4.000 m³ per year is considered realistic.



Measuring Principle

The measuring principle of the raw density measuring system StenOgraph is based on a combination of x-ray transmission and forward scatter. The imaging geometry is designed to determine the density profile of a moving panel directly at the outlet of a continuous press.

A narrowly focused x-ray beam (1) penetrates the cross section of the moving panel (2), preferably at an angle of 45°. A scanning detector system (3) records the density-dependent scattered radiation along the plane of the panel and a stationary detector (4) records the transmitted radiation.

By combining both signals, the density of any part of the panel cross section is calculated directly. Thus, a scan of the full thickness as well as a sub-scan of selected areas can be made.

Construction of the System

The main body of the raw density profile analyser consists of a solid aluminium O-frame. All cable connections leading to the components like x-ray tube and detector unit are installed within the O-frame to prevent external damage or influence.

The housing above the panel is equipped with a swing-out mechanism to protect against the impact from blisters of up to 200 mm (8 inches) height.

The measuring device itself is protected from dust and moisture by a positive pressure air system.

A water cooling function is included in the x-ray tube which is continuously monitored through temperature sensors. If the temperature limit is exceeded, the x-ray tube is automatically switched off.



Software

The visualisation software of all GreCon systems is based on Windows®. The software of the StenOgraph consists of the following program modules:

Recipe Management

All system and product parameters required for one product type are stored in the protocol data base.

Calibration

The quality of the measuring results depends on consistent conditions during measurement. Because this cannot be reliably ensured under industrial conditions, the GreCon Raw Density Profile Analyser is equipped with a calibration check function. During this procedure, the measured profile is compared with a reference profile.

Visualisation

The core of the software package is the visualisation software. It records all measured values and processes them graphically. The simple menu structure makes an intuitive operation possible.

Clear information and graphics enable the operator to quickly and effectively adjust the online production process. Using a waterfall graphic (optional), it is possible to represent the last six raw density profiles in order to monitor the development of the raw density profile during production start-up and the running production process. Standard profiles are faded in so that deviations from the rated value can be easily recognised.

Software Module FB

The software module FB is used for better representation of local non-homogeneities of the raw density profile of thin panels. Local non-homogeneities are both surface layers and low density areas in the transition area of surface layer and core layer.

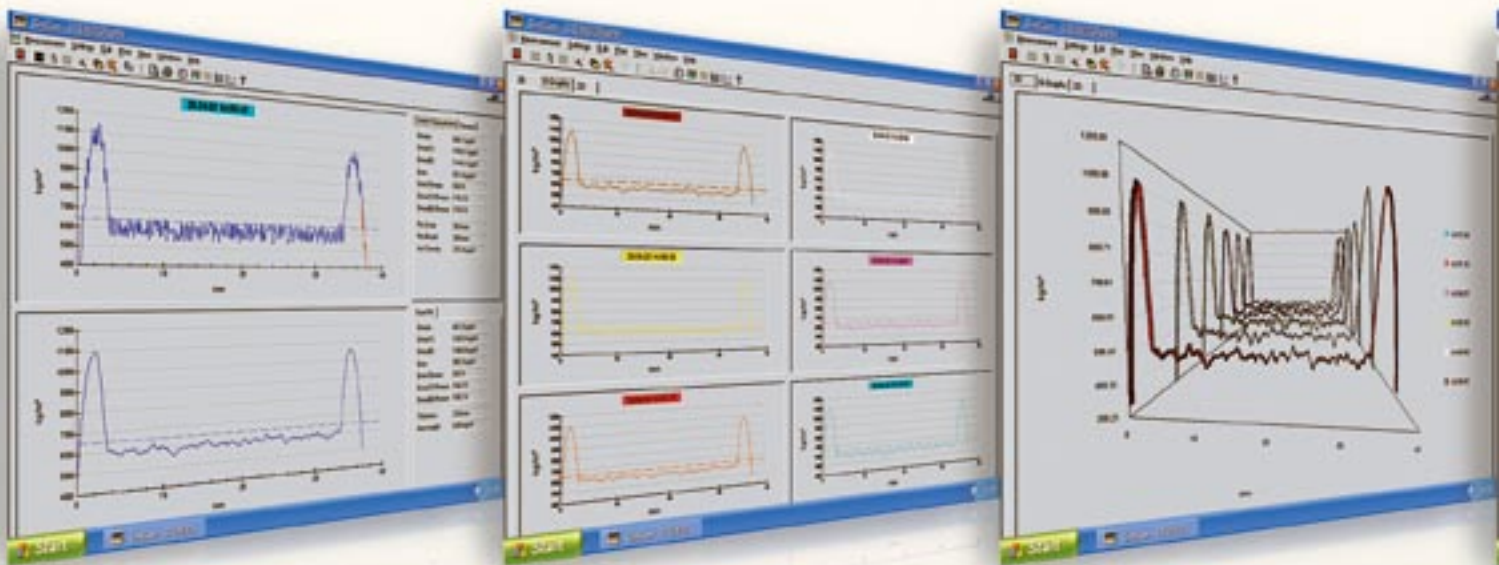

Graphical Display

Comparison of several Measurements

3D Waterfall Graphic

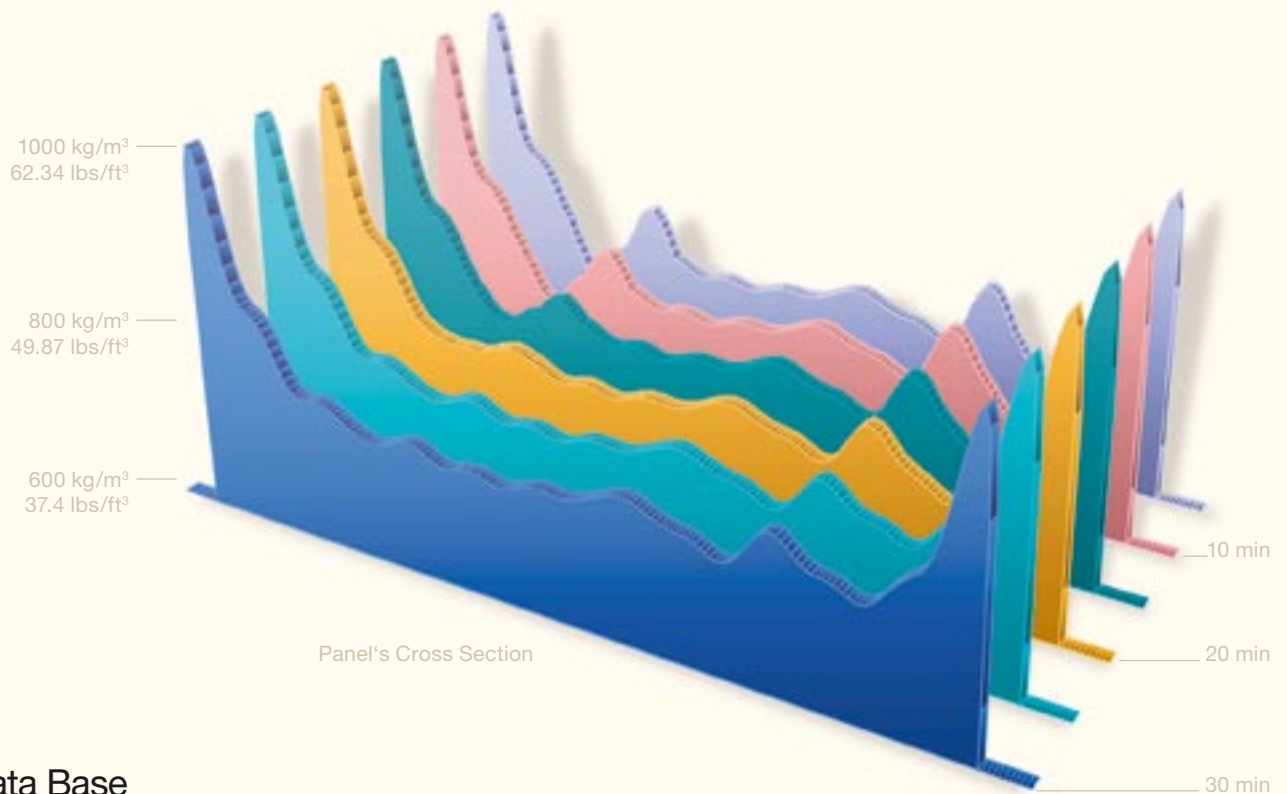

History Data Base

In this data base, measured values can be stored and exported to other file formats for further processing.

Network Connections

Besides the local evaluation and recording of measured values by the visualisation computer, the StenOgraph can be linked with higher-ranking process control systems via different interfaces, such as NET DDE, Allen Bradley Ethernet or Ethernet with TCP/IP or H1 BUS protocol.

Online After-Sales Service

GreCon measuring systems are equipped with a modem for a direct connection between the GreCon after-sales service and the measuring system. Changes in parameters, software updates and support are all possible online.

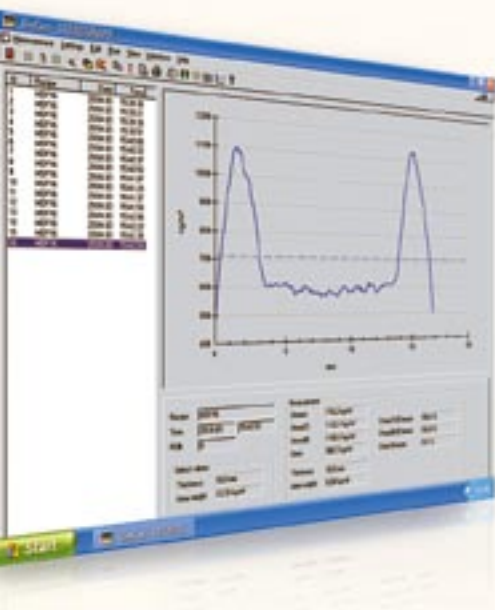

History Data Base with Graphical Display

Technical Specifications

- Mains voltage:..... 230 V / 115 V
- Frequency: 50 Hz / 60 Hz
- Power consumption:.....approx. 5 kVA
- Compressed air supply:..... 6 bar
90 psi
- Compressed air consumption:approx. 1.800 l/h
0.001 cfm
- Panel thicknesses:3 up to 42 mm
0.12 up to 1.75 inch
- Measuring velocity:..... adjustable
0.5 up to 10 s/mm panel thickness
0.02 to 0.4 sec/inch panel thickness

References

- Particleboard / MDF board / OSB board / HDF board

Hardware Advantages

- O-frame is easily adapted to plant configuration by the modular design
- The motorised sensory array allows a choice of various measuring positions
- Calibration position outside of the roller conveyor, i.e. calibration and maintenance work is possible during running production

Software Advantages

- Windows® operating system
- Recipe data base for automatic production change-over
- Storage of the measured data in a history data base
- Preparation of network connection is standard
- Telediagnostic service through GreCon after-sales



Detailed View on Detector Unit

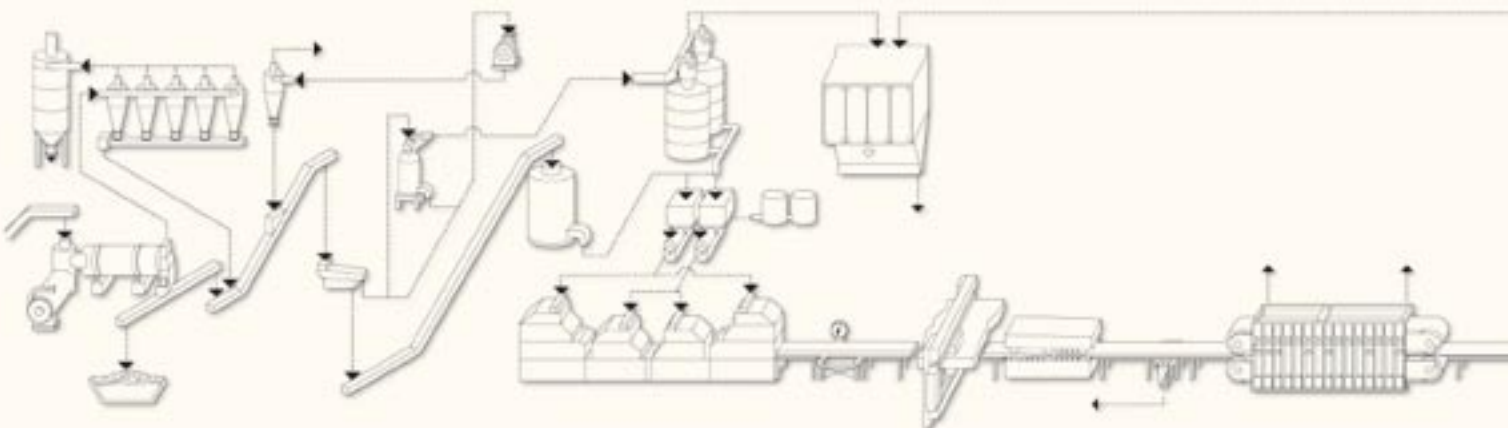

Measuring Position

The measuring position is at the outlet of a continuous press. X-rays are directed through the panel. The density distribution is evaluated from the absorption and distribution of this radiation. The profile is displayed on a screen in the same way as a laboratory density analyser. The measuring time takes just a few seconds, depending on the panel's thickness. Measurement is made in the same position for every panel.

The installation place is at the exit of a continuous press, i.e., the density profile is determined before (in exceptional cases also after) the cross-cut saw.



Detailed View on complete Measuring Transducer

Reducing Starting-up Periods

Starting-up periods of continuous production lines are very costly and time-consuming whereas the raw density profile analyser will pay off within only a few months due to reduced starting-up periods and an increased productivity.

Safety is important to GreCon

All shielding of x-ray sources surpass governmental requirements. A dust hood protects all moving parts. All cables are installed in the O-frame to protect them from damage.

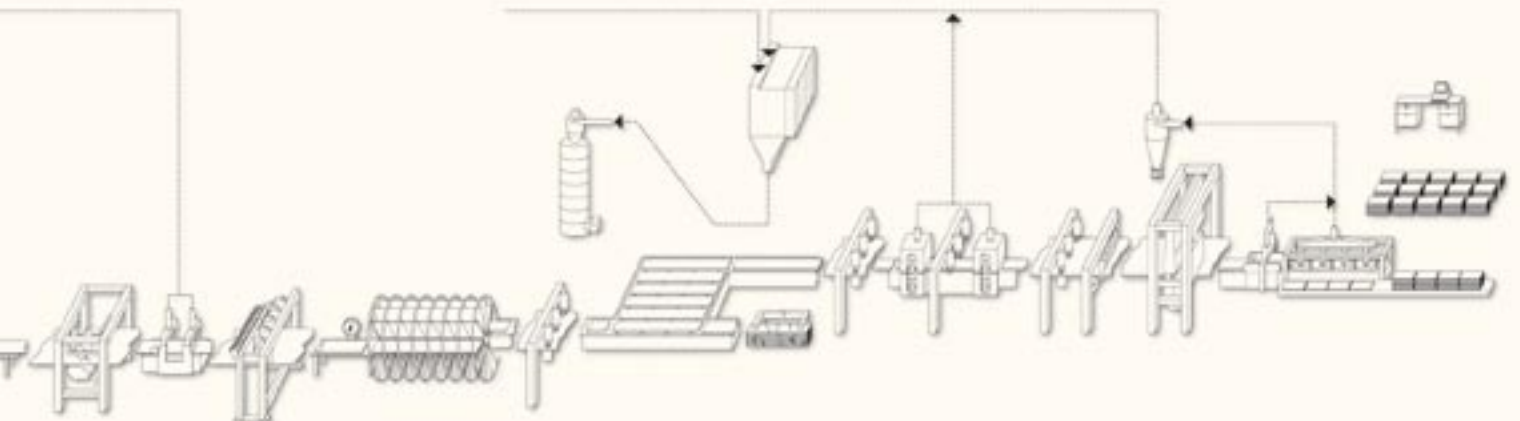

GreCon



Fagus Factory, constructed by Walter Gropius in 1911

GreCon, Inc.
15875 S.W. 74th AVE.
TIGARD
OR 97224

TEL: +1 (503) 641-7731
FAX: +1 (503) 641-7508
EMAIL: sales@grecon-us.com
WEB: www.grecon-us.com
