

DMR 3000

Online Thickness Gauge for Quality Assurance
with Rhomboidal Technology



GreCon®

Production and Quality Control with the GreCon Thickness Gauge

Exploit all reserves of your production, homogenise your process, increase the availability of your equipment and increase your profit.

Fluctuations in panel thickness and deviations from nominal values reduce quality. Your customer will identify these as defects in your product.

The GreCon Thickness Gauge DMR 3000 provides accurate information to ensure a high quality standard by a quick adjustment of the production process.

All measured data can be transferred to an automatic process control or press control system. Thus, time periods required for product changes or production start-ups can be reduced and rejected material minimised with the DMR 3000.



ct-frame

ct-Frame

To achieve a continuous system availability, the DMR 3000 is equipped with a ct-frame. This basic construction of the measuring system makes an installation after saws or in continuous productions possible.

The system can be calibrated at any time by moving the ct-frames sideways out of the production line. Maintenance, diagnostics and repairs can be carried out during the running production.

Futhermore, the mobile construction of the system allows an escape run in case of big blisters and thus prevents the measuring system from being damaged.

Measuring Principle

There are two measuring principles to choose from, depending on the product structure, installation area and desired results. The laser measurement is primarily used for traversing measurements and soft materials. For solid materials and rough environments, the contact measuring system is used.

A consistent measuring accuracy of both systems is ensured by an automatic calibration system.

Laser Measurement

A laser beam is projected onto the material to be measured and a change in thickness changes the angle of the reflected laser beam. This angular change is used to calculate the thickness. The laser measuring heads are installed in pairs above and below the material to be measured.

If necessary, the measuring heads can be protected against dust and heat with an automatic air purge system.

Contact Measurement

High-precision rollers contact the material and convert thickness variations into vertical motion within the transducer. The measurement is achieved by means of an optical element inside the transducer heads.

The measuring heads are installed in pairs, opposite each other, above and below the panel to ensure accurate measurements, even during bending or vertical movement of the panel.

To protect the measuring heads against mechanical damage, through blisters, for example, they are equipped with relatively big rollers. The top heads have special inclined inlet rails to avoid damage.



Contact measurement with ct-frame

Construction of the System

Up to 10 measuring tracks can be mounted on a frame, which is made out of patented aluminium profiles. The cable and compressed air ducts are integrated in the profile and thus protected against the surroundings.

Set-Point Positioning

The rhomboidal wing is a special mechanical protection and positioning system for contact measurement over the entire panel length. It allows panels to enter the measuring system at transport speeds of up to 200 m/min / 650 fpm with the heads in closed mode.

Furthermore, the measuring heads will stay in their positions after the last measurement, which reduces the mechanical strain of both the panel edges and the measuring heads. The consumption of compressed air is reduced. Even in case of a compressed air failure, the heads will stay in their last position.

Combination with other Measuring Systems

Since the thickness gauge is a modular system, it is possible to change the measuring requirements at any time. The system can be combined with the Ultrasonic Camera UPU 3000 and a Board Scale and thus provide a quality assurance station. This combination is primarily used after continuous presses.

Software

The visualisation software of all GreCon measuring systems is based on Windows. The software of the DMR 3000 consists of the following program modules:

- Recipe Management

This is a product data base in which different panel types and production parameters, which are relevant for the measuring system, can be stored.



Rhomboidal wing

■ Visualisation

The core of the software package is the visualisation software. It records, stores and graphically represents all measured data. The simple menu structure, which is identical for all GreCon measuring systems, makes an intuitive operation possible. Clear information and graphics enable the operator to quickly and effectively adjust the running production process. If a board scale is integrated, weight values and average raw densities will be visualised, as well as the thickness values.

■ History Data Base

This data base stores the measured values and provides a function to export them to other file formats for further processing and evaluation.

Network Connections

For the data transmission to higher-ranking process control systems, different interfaces, such as NET DDE, Allen Bradley Ethernet or Ethernet with TCP/IP or H1 BUS protocol, are available.

Online After-Sales Service

GreCon measuring systems are equipped with a modem, by means of which a direct connection to the GreCon after-sales service can be made. Support, changes in parameters, software updates and trouble shooting are all possible online.



Visualisation of thickness values

Recipe management

Technical Specifications

- Mains voltage:..... 230 V / 115 V
- Frequency: 50 Hz / 60 Hz
- Power consumption:..... 750 VA
- Compressed air supply:..... 6 bar / 90 psi
- Compressed air consumption: ... approx. 3.5 l / 0.12 cf
per measurement
(with 5 measuring heads
without rhomboidal wing)
- Max. number of heads
per electronics evaluation:..... 20 (10*1)

Measuring accuracies:

- Contact measurement
standard:..... $\pm 1/100$ mm, ($\pm 2/100$ mm^{*1}) /
 ± 0.0004 in (± 0.0008 in^{*1})
- Contact measurement
option: $\pm 1/1000$ mm, ($\pm 2/1000$ mm^{*1}) /
 ± 0.00004 in (± 0.00008 in^{*1})
- Laser measurement
for 70 mm measuring range:..... $\pm 1/10$ mm^{*2} /
 ± 0.004 in^{*2}

^{*1} for 2-side measurement
(pairs of measuring heads)

^{*2} depending on the measuring range

References

- Particleboard
- Fibreboard
- OSB board
- Plywood
- Gypsum board
- Mineral fibre
- Wood cement
- HDF board
- Hardboard
- Solid wood
- Veneer
- Plexiglass
- Rubber
- Linoleum
- Wet fibreboard

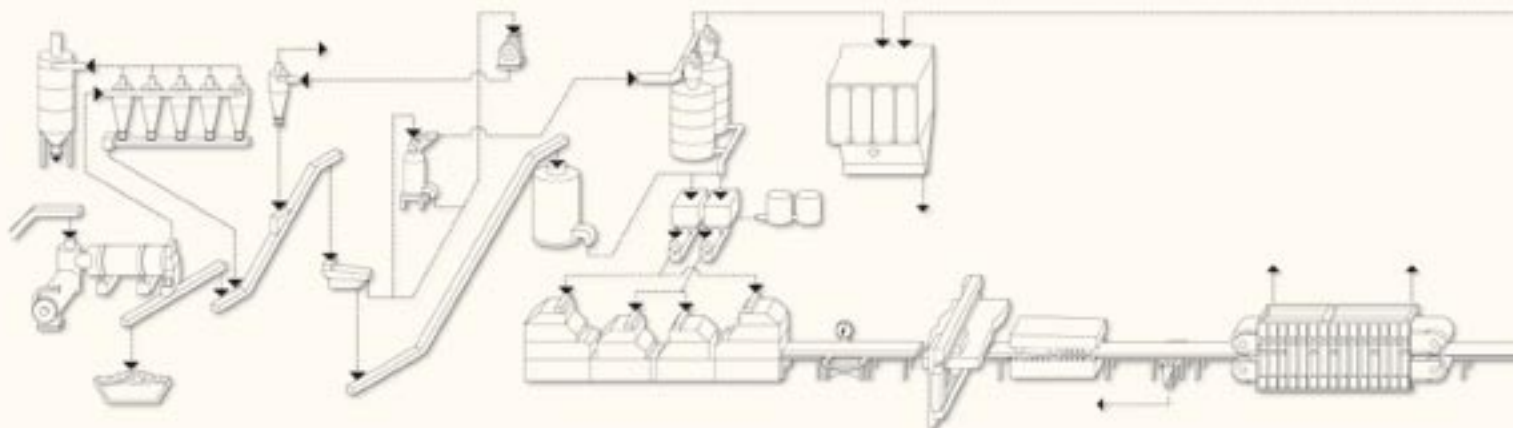

After the Press

In the wood based industry, thickness gauges are combined with GreCon Ultrasonic Cameras UPU 3000 and Board Scales to a quality assurance station. Data is recorded and evaluated by one central visualisation computer.

Combined System for Press / Star Cooler

Through the combined installation of thickness gauges after the press, and the following star cooler, the thickness values of individual panels are recorded in different positions of the production process and can be compared. Thus, exact information about the distention or “spring-back” behaviour of panels can be obtained.

Sanding Line

A combination of up to three thickness gauges is used for final quality control in the sanding line. For example: a 1-track thickness gauge is installed before the calibration sander, a 2-track system after the calibration sander and a 3-, 5- or 7-track system after the finishing sander. Besides quality control, the measured data can be used to adjust the sanders to the current thickness values.



Final quality control after the sanding line

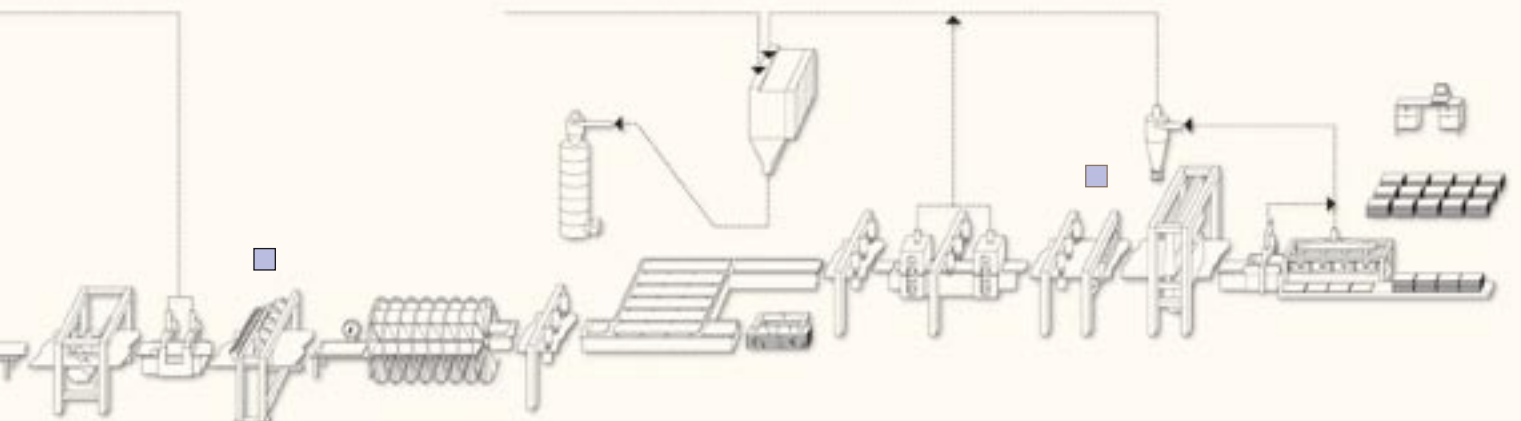

GreCon



Fagus Factory, constructed by Walter Gropius in 1911

GreCon, Inc.
15875 S.W. 74th AVE.
TIGARD
OR 97224

TEL: +1 (503) 641-7731
FAX: +1 (503) 641-7508
EMAIL: sales@grecon-us.com
WEB: www.grecon-us.com
