

DIEFFENSOR

Inline Mat Scanner for Steel Belt Protection
and Optimisation of the Mat Forming



GreCon®

Steel Belt Protection

The GreCon mat scanner DIEFFENSOR precisely differentiates between harmless small foreign bodies and those which may damage the steel belt. DIEFFENSOR recognises metallic and non-metallic foreign bodies of high density located in fibre, chip or OSB mats, such as glue lumps, super-dense fibre lumps. It even detects plastic or aluminium articles which cannot be recognised with standard metal detectors or magnets. Foreign bodies may cause irreversible damage to the steel belts of a continuous press, especially when thin panels are produced. DIEFFENSOR recognises the shape and mass of foreign bodies, stores 3D pictures and trends for later evaluation.

Using DIEFFENSOR, the steel belts of a press can be effectively protected against permanent damage by high density non-metallic foreign bodies.

Detectable and Influenceable Factors

The following factors can be clearly optimised by using the DIEFFENSOR:

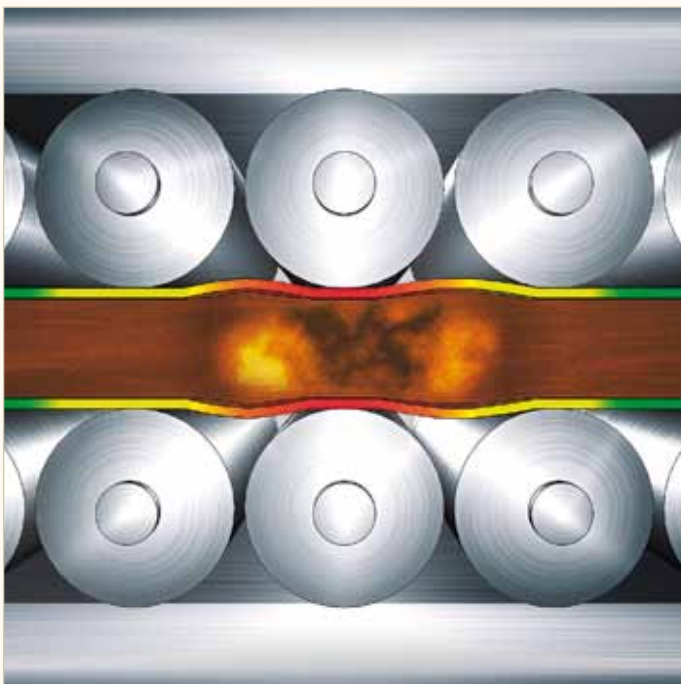
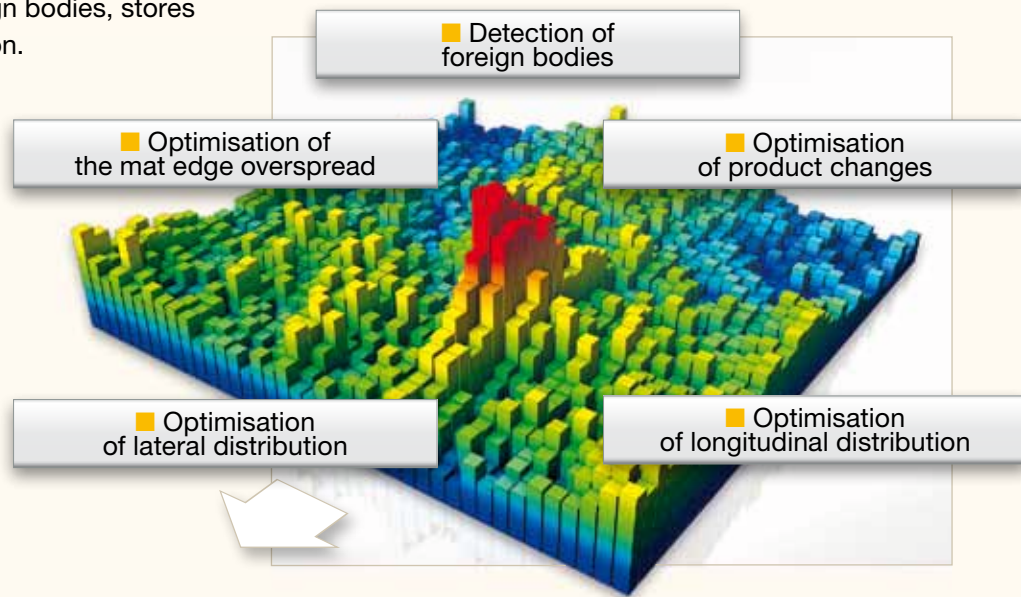

Strains on steel belt



DIEFFENSOR in press line

Weight Per Unit Area and Material Distribution

DIEFFENSOR determines, with high resolution and over the entire mat width, the weight per unit area as well as the material distribution of the fibre, chip or OSB mat.

Exact graphical and numeric representations enable the operator to adjust the forming process in due time to achieve consistent panel quality while the use of material and energy is optimised.

The process-related systematic process fluctuations are visualised and can be considerably reduced. Experience shows that material savings of at least 1 to 3 % can be realised.

The permanent monitoring of the mat distribution across the production direction prior to the main press ensures an optimum production flow; belt tracking caused by imbalances in the mat can be prevented. The recorded measured data makes it possible to easily trace production processes, log them, and evaluate them over time.

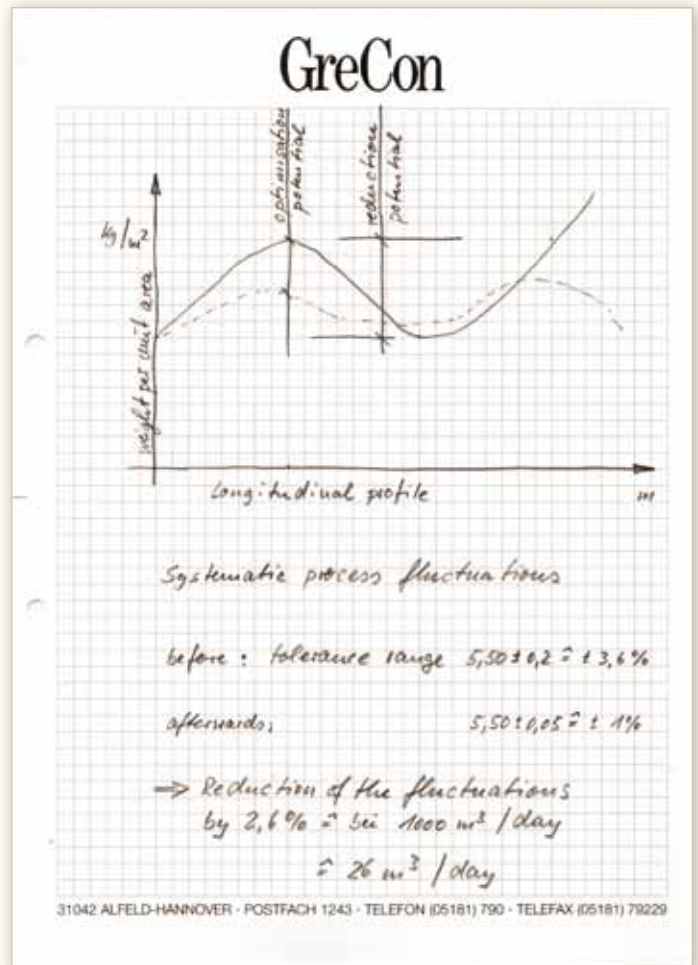

Potential of systematic process fluctuations



Measuring Principle

The DIEFFENSOR works in a non-contact method. The x-ray sources are installed above, and the high-precision sensors below the material to be measured. Depending on the specific density and the amount of material, more or less x-radiation is measured by the sensors. Measured values are derived from these data.

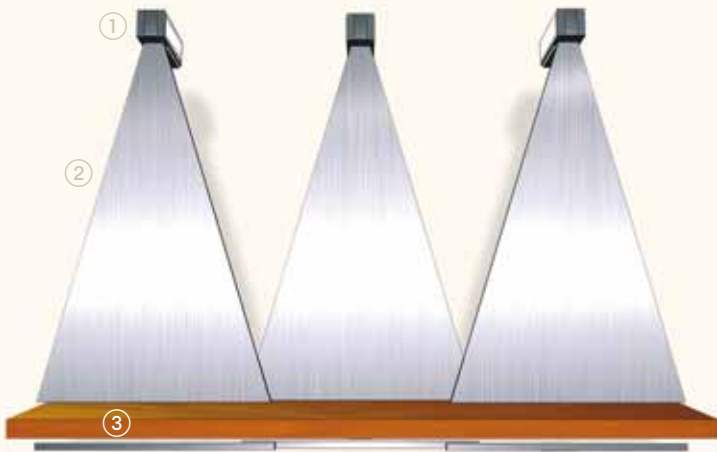

- ① X-ray source
- ② Tube
- ③ Fibre mat

Calibration

The system is equipped with an automatic calibration. The DIEFFENSOR is calibrated to a reference sample at regular intervals.

Online After-Sales Service

GreCon measuring systems are equipped with a modem or VPN, which provides a direct connection to GreCon service when needed. Support, changes in parameters, software updates and trouble shooting are all possible online.

Software

The visualisation software of all GreCon measuring systems is based on Windows. The software of DIEFFENSOR consists of the following program modules:

Recipe Management

This is a product data base in which different panel types and production parameters, which are relevant for the measuring system, can be stored.

Network Connections

For the data transmission to higher-ranking process control systems, different network connections, such as OPC or ODBC, are available.

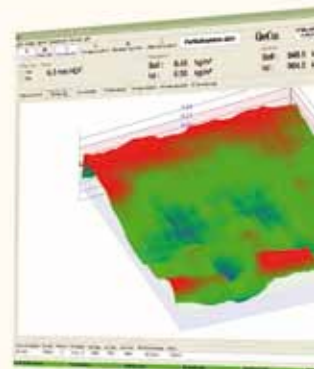

Visualisation

The core of the software package is the visualisation software. It records, stores and graphically represents all measured data. The simple menu structure, which is identical for all GreCon measuring systems, makes an intuitive operation possible.

Clear information and graphics enable the operator to quickly and effectively adjust the running production process. The measured values are represented as a 3D picture. Out of tolerance limits are marked with changes in colour and tolerance relays, with voltage-free outputs, are activated.

SQL Data Base

This data base stores the measured values and provides a function to export them to other file formats for further processing and evaluation. A uniform data structure provides easily accessible data for process control systems.

Steel Belt Protection

The software, specifically developed for this task, provides a highly sensitive inspection of the fibre mat for detecting unwanted foreign bodies. Adequate precautions can be activated through quick signals given to the press control.



Technical Specifications

- Measuring ranges:..... 1 to 50 kg/m²
0.2 to 10.24 lbs/sq ft
- Mat speed:..... 0 to 2.500 mm/s
0 to 0.1 in/s (or 5.9 in/min)
- Mat height: 0 to 500 mm
0 to 20 in
- Mat width:up to 4.000 mm
13 ft

- Recipe administration
- 3D representation
- OPC interface for connection to process technology (PLC)
- Storage of the measured data in an SQL data base
- Preparation for network connection is standard
- Telediagnostic service through GreCon after-sales service
- Visualisation with various representations of the measured values

Technical Features

- Non-contact measurement
- Little installation space
- High-quality housing meets radiation protection standards

Application Fields

- Particleboard, MDF board, HDF board, OSB
- Insulating materials



DIEFFENSOR in MDF line



DIEFFENSOR in HDF line

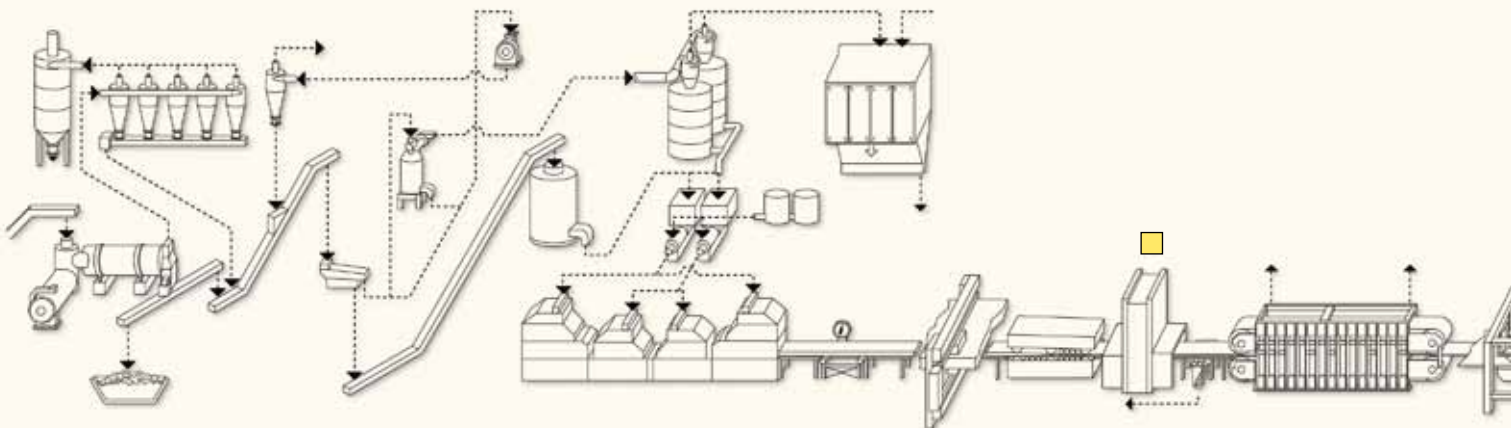

Applications

For MDF, particleboard and OSB production, DIEFFENSOR is installed prior to the main press.

An additional application is measurement of boards that are ready pressed. This is particularly interesting when a measurement of the material distribution prior to the press is impossible or when additional information is required.



DIEFFENSOR in OSB line

Why GreCon



- Complete determination of the weight per unit area
- Longer life of the steel belts
- Complete picture of the spreading quality
- Improved product quality
- High-resolution data storage for statistical evaluation
- Long-term storage of production data

Your Benefit



- The DIEFFENSOR is a measuring system incl. an analysis tool to optimise the material consumption
- Panel weights can be predicted
- Quality features can be shown by means of the inline sample measuring mode and are demonstrable by means of a laboratory interface
- Hidden production failures occurring in the upstream production process can be detected and eliminated
- Process-related, systematic deviations are shown and can be reduced
- In most cases, material, wood, glue and energy can be reduced by at least 1 to 3 %

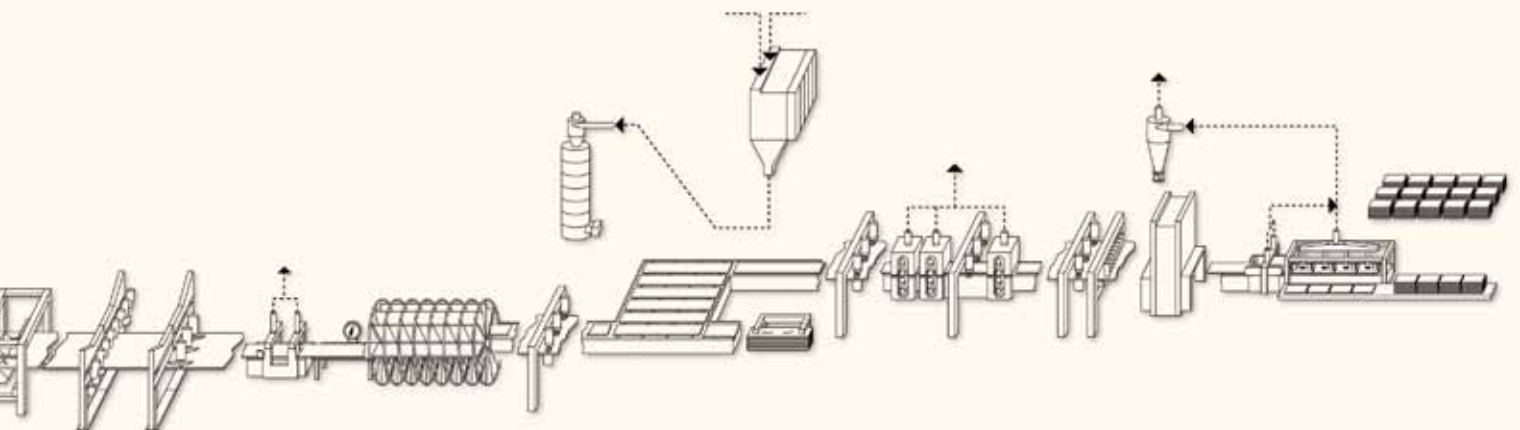



OUR HEADQUARTERS AT ALFELD - BUILT BY WALTER GROPIUS IN 1911

GreCon

15875 SW 74th Ave.
Tigard, Oregon 97224

TEL: (503) 641-7731
FAX: (503) 641-7508
E-MAIL: sales@grecon-us.com
WEB: www.grecon-us.com

