

Establishing the Raw Density with the Laboratory Density Profile Measuring System

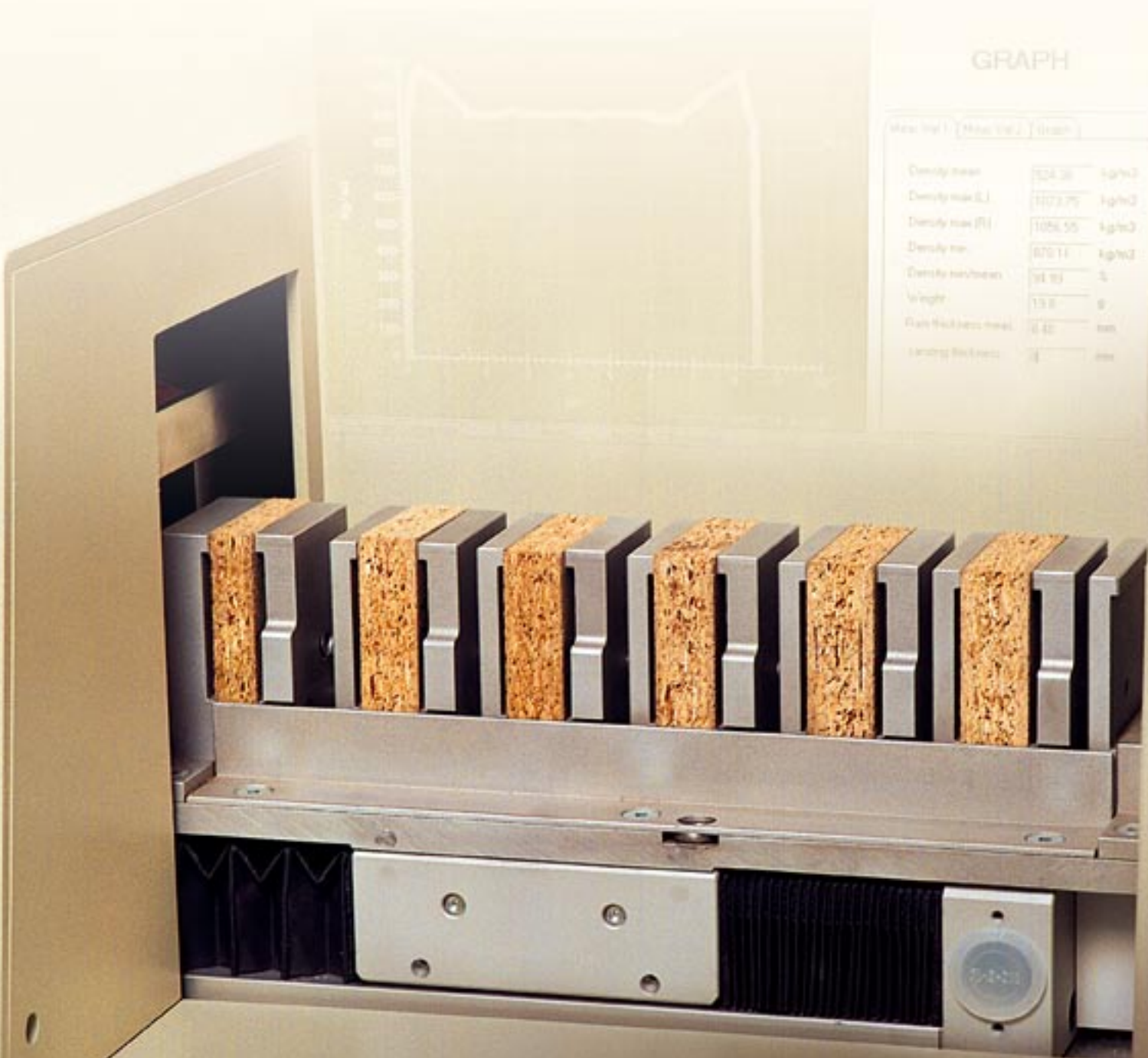

Raw Density Measuring in a Laboratory, using modern X-ray Technology

The data obtained from the laboratory analysis is imperative to verify the information received from the various on-line measuring systems.

100 Times faster, 10 Times more accurate

By using modern X-ray technology, the GreCon laboratory density profile measuring system works 100 times faster and 10 times more accurately than traditional systems using a radiation device.

Highly accurate, rapid and easy measuring of the density distribution is available for various wooden boards. This is based on an optimized measuring source consisting of an X-ray semiconductor detector combination that makes it possible to carry out highly accurate measurements with a speed of up to 5 mm per second.

If the DA-X is combined with other measuring systems, the laboratory work can be even more effective and easy. All the laboratory data obtained are evaluated by a visualization computer and displayed.

Configuration of the DA-X

The DA-X is configured as a complete laboratory system, consisting of an ergonomically designed workstation, the measured value data logger, a scale, an electronic caliper and a visualization computer.

The workstation has space for all components of the measuring system. In addition, it offers sufficient space for „manual“ data processing. The printer and the PC are safely housed in a side compartment. The connection cables are routed via integrated cable ducts.



Overall view of the entire system

The data logger consists of the controls for the motor driven sample carrier, the X-ray generator and the measuring unit. To protect the operator, the moving parts have been covered by a fibre-glass hood. The effective screening of the measuring area has been approved and restricts the X-rays to the measuring chamber.

A scale and an electronic caliper are connected to the evaluation system of the DA-X. The mechanical dimensions and the weight of the sample to be measured are logged in with the push of a button and automatically stored with the other sample data.

By using a sample holder, several samples taken from the same board or from different boards can be evaluated in a single measuring process. Depending on the thickness of the boards, there are holders for one, three or six samples. For easier handling, the sample holders can be removed from the carrier to insert board samples.

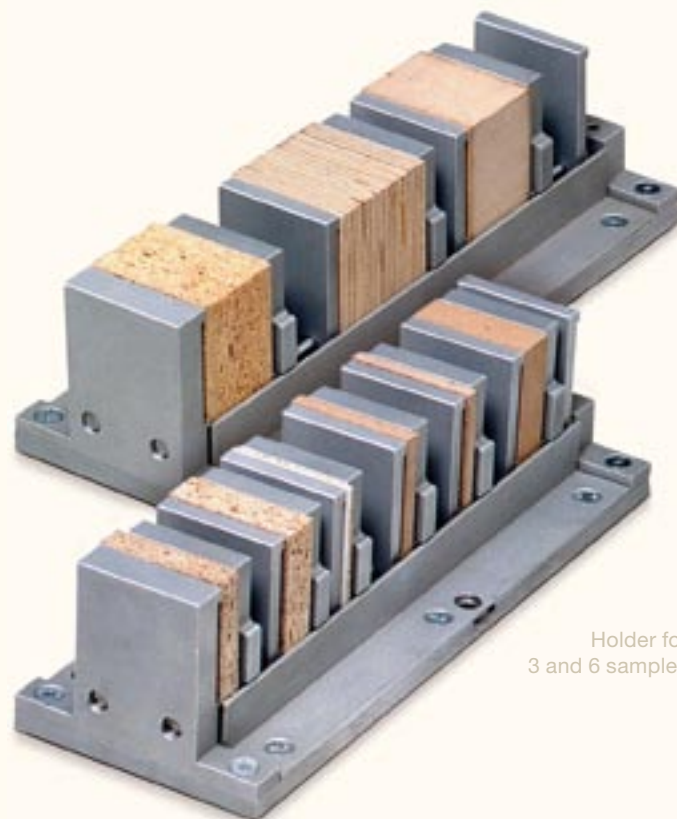

Holder for 3 and 6 samples



Electronic measuring caliper and scale

The Measuring Process

Measuring takes place in three simple steps. First the known production data of the board samples are entered into the visualisation computer.

This data is then allocated to the dimensional and weight values determined with the aid of the electronic caliper and the scale.

The holder with wood samples is inserted into the carrier and the measurement is initiated. Within a few seconds, the measured values are available in numerical and graphical form for further analysis.

Software

The extensive DA-X software is based on the Windows operating system and the simple menu structure makes intuitive handling of all program modules possible.

The most important function of the software package is visualization. All the data recorded are protocolled and graphically processed. The information obtained is automatically stored in a database and can be called up for further analysis at any time. The integrated export function can be utilized to make the data available for other programs, for example, tabulation.

Important information on the current measurement, including

- average raw density
- maximum raw density of the top layer
- maximum raw density of bottom layer
- actual position of sanding surface

are shown in numerical form on the screen after the measuring process and their position identified within the raw density profile.

There are also comprehensive functions for an exact evaluation and analysis of the raw density profiles:

- Zoom into sections of the raw density profiles

Individual sections of the profiles can be continuously enlarged or reduced for a more detailed view.

- Comparative measurements of various board samples

Measuring graphs can be overlaid on the screen. This facilitates a comparison of the sanded and unsanded boards or of samples from different production periods. The measuring graphs are clearly colour-differentiated.

- Averaging of different measured values

The measured results of various board samples can be averaged by using an arithmetic function. This improves the assessment of production periods.

The data obtained and the exact analysis of the bulk density profile allow further conclusions to be drawn about the board characteristics and their utilization, as well as the production process.

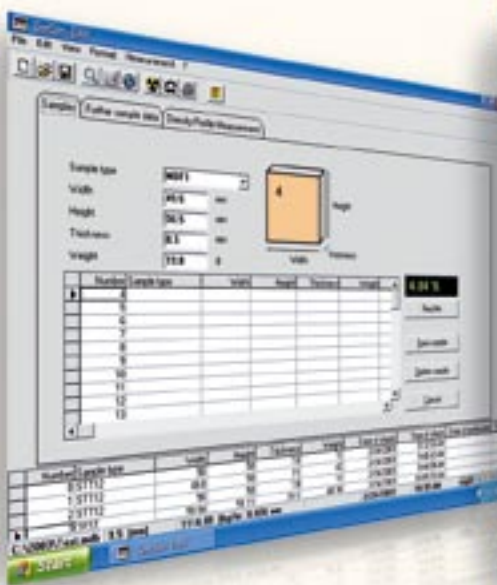

Measurement of sample data

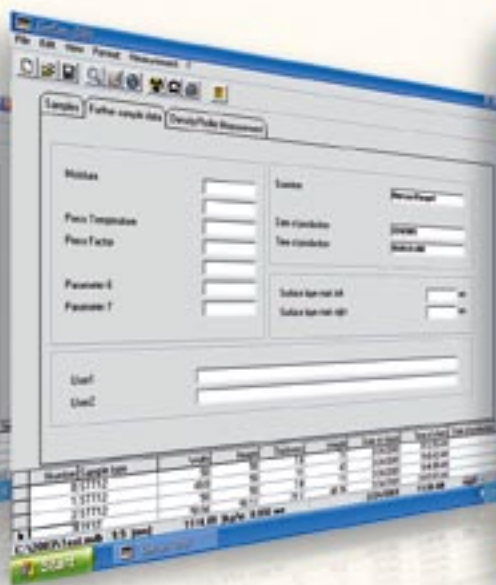

Measurement of additional sample data

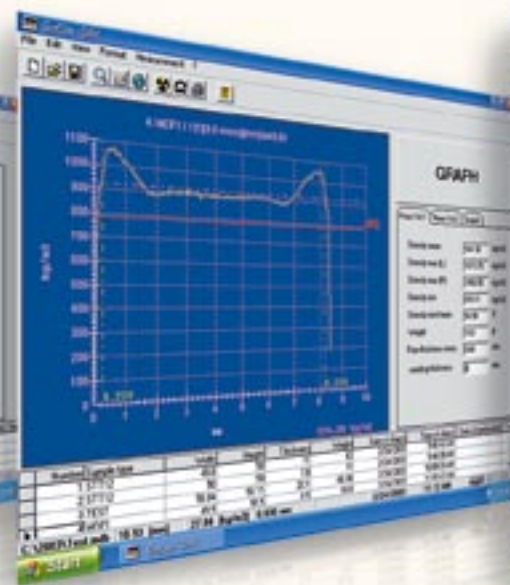

Graphical representation of general sample data

Technical Specifications

- Supply voltage: 230 V / 115 V
- Frequency: 50 Hz / 60 Hz
- Power consumption: 750 VA
- Sample dimensions: 50 x 50 mm ± 1 mm
2 inch x 2 inch ± 0.04 inch
- Material sample: Wood compounds
- Measuring range: up to 1500 kg/m³
94 lbs/cuft
- Feed speed: from 0,05 to 5 mm/sec
0.002 to 0.2 inch/sec
- Increments: 20 µm
- Calibration: semi-automatic
with internal calibration
- Measuring accuracy: ± 1% of measuring range
- Number and maximum sample thickness for:
 - Holder 1: 6 samples up to 20 mm
up to 0.75 inch
 - Holder 2: 3 samples up to 50 mm
up to 2 inch
 - Holder 3: 1 sample up to 150 mm
up to 6 inch (optional)
- Ambient temperature: 15 to 25°C
- Relative humidity: max. 60 %

References

- Particleboard / MDF board / OSB board / HDF board / Hardboard

Hardware Advantages

- Solid basic construction
- Highly accurate linear drive with 1,25 µm increments
- X-ray technology (no permanent radioactive source)
- Measuring resolution 20 µm (local resolution)
- Measuring speed of 0,05 to 5 mm/s
(eg. a 19 mm sample is measured in 4 seconds)
- Various sample types such as: chipboard, MDF, OSB, LVL, laminated wooden boards, but no gypsum- or cement-bonded boards
- Geometrical sample data are transmitted via an electronic caliper
- The weight of the sample is electronically recorded with the aid of a scale

Software Advantages

- Windows® operating system
- Software package, including tabulation (Excel)
- Multiple graphics in 3 D, cascade or colour progression (graph comparison)
- Export of graphical data using Excel, etc.
- Simple operation of software
- Seamless zooming of graphics
- Network connections, standard
- Remote diagnostics via GreCon customer service

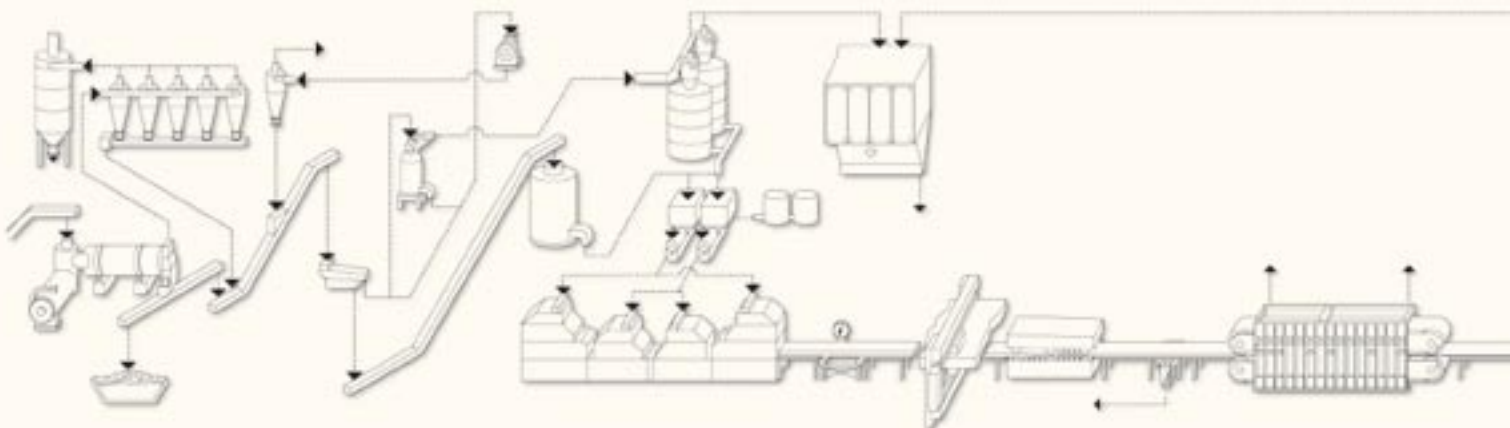

Interface with other Systems

Ever-increasing production capacities have brought about a corresponding increase in the number of board samples to be measured, as well as the laboratory service and equipment requirements. Efficient laboratory work is guaranteed by interfacing the DA-X with other laboratory measuring systems.

MWF 3000 LD

The laboratory moisture measuring system MWF 3000 LD can be fully integrated into the DA-X system. This system works on the microwave measuring principle and automatically determines the moisture content of the entire board sample, after which the measuring result is stored with the other sample data.



Moisture Analyser MWF 3000 LD

StenOgraph

A particularly useful combination is the use of the laboratory raw density profile measuring device DA-X and the on-line raw density profile measuring device StenOgraph. When used as part of the continuous production process, the StenOgraph provides all the data required to optimize production. If unusual developments should be observed in certain board ranges, these can be investigated and accurately evaluated in the laboratory by using the DA-X.

Bondcheck / Labrob

If the data and information from the raw density profile are viewed in correlation with the mechanical properties such as the transverse tensile strength, the shear strength and bending strength of the board samples, the DA-X can be linked to the Bondcheck automatic board-testing system or the Labrob board testing device.

In this process, the information obtained from the various devices is collected in a PC and evaluated.

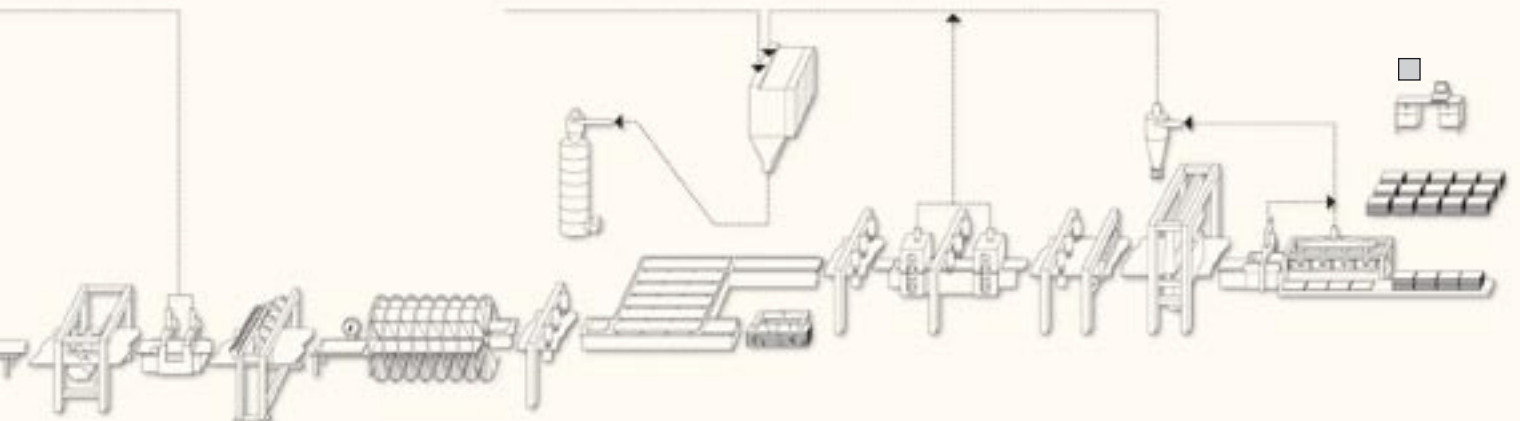

GreCon



Fagus Factory, constructed by Walter Gropius in 1911

GreCon, Inc.
15875 S.W. 74th AVE.
TIGARD
OR 97224

TEL: +1 (503) 641-7731
FAX: +1 (503) 641-7508
EMAIL: sales@grecon-us.com
WEB: www.grecon-us.com
