

**BWQ 5000**

Measurement of the Material Distribution  
with the Inline Weight Per Unit Area Gauge



GreCon®

## Inline Weight Per Unit Area Measurement with X-Ray Technology

The GreCon Weight Per Unit Area Gauge BWQ 5000 ensures a high product quality while the use of raw material and energy is optimised.

The properties of particleboard, MDF and OSB board depend considerably on the exact spreading of the mat. The main goal of using a BWQ 5000 is the optimisation of material consumption. A heavy board is still acceptable for the end customer, but the material and production costs are much too high for the manufacturer. A board that is too light has only poor quality properties.

The BWQ 5000 monitors the material distribution of loosely spread or pre-pressed wood based mats. Graphical and numeric representations enable the operator to adjust the forming process to achieve consistent panel quality while the use of material and energy is optimised. The permanent monitoring of the mat distribution across the production direction prior to the main press ensures an optimum production flow; belt tracking caused by imbalances in the mat can be prevented.

The recorded measured data makes it possible to easily trace production processes to expose optimisation potentials. With the BWQ 5000 information combined with other process data in a higher-ranking process control system, further optimisation potentials are revealed.



Measurement transducer in the calibration position

## Measuring Principle

The weight per unit area gauge works in a non-contact method. An x-ray source is installed below, and a high-precision sensor above the material to be measured. Depending on the specific density and the amount of the material, more or less x-radiation is measured by the sensor. This is a measure for the weight per unit area (kg/m<sup>2</sup> / lbs/f<sup>2</sup>).

## Automatic Calibration

The quality of the measuring results essentially depends on constant conditions during measurement. To obtain a high measuring accuracy, the BWQ 5000 is calibrated automatically at regular intervals. For automatic calibration, a sample is placed in the calibration position, which is located near the material flow.

## Operation Modes

The GreCon Weight Per Unit Area Gauge can operate in three different modes.

The measurement of the material distribution across the production direction is done in cross mode and in both directions. Should a special zone be analysed more precisely, or, should the longitudinal profile be measured, the measurement transducer can measure in stationary mode at a certain position. Should several positions be analysed one after the other, this is done in step mode at pre-determined time intervals or at certain points on the mat.

## Construction of the System

The basic construction of the traversing weight per unit area gauge consists of a solid aluminium O-frame. The profile of the O-frame was developed especially for the BWQ 5000. All driving elements are integrated in this profile. High-quality rails for the top and bottom measuring slides ensure precise guidance. The two measuring slides are driven by toothed belts, which are linked with the motor via a divided spacer shaft and a safety clutch.

The measuring unit is moved by a variable-speed A.C. frequency converter and gear motor.



Measurement of a fibre mat

# Software

The visualisation software of all GreCon measuring systems is based on Windows®. The software of the traversing Weight Per Unit Area Gauge BWQ 5000 consists of the following program modules:

## ■ Recipe Management

This is a product data base in which different panel types and production parameters, which are relevant for the measuring system, may be stored.

## ■ Visualisation

The core of the software package is the visualisation software. It records all measured values and processes them graphically. The simple menu structure, which is standard for all GreCon measuring systems, makes an intuitive operation possible.

Clear information and graphics enable the operator to quickly and effectively intervene in the running production process. The measured values are represented as a profile. Since measurement can be effected in three different operation modes, the mode determines how the profile is represented: as cross profile, as longitudinal profile or a combination of both profiles.

Out of tolerance limits are marked with changes in colour and tolerance relays, with voltage-free outputs, are activated.

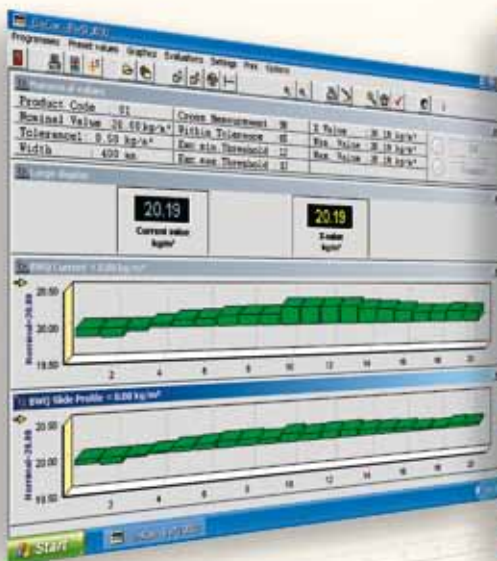

Graphical representation



Selection of the operation mode



Recipe management 1

## ■ SQL Data Base

This data base stores the measured values and provides a function to export them to other file formats for further processing and evaluation. A uniform data structure provides easily accessible data for process control systems.

## Network Connections

For the data transmission to higher-ranking process control systems, different network connections, such as OPC or ODBC, are available.

## Online After-Sales Service

GreCon measuring systems are equipped with a modem or VPN, which provides a direct connection to GreCon service when needed. Support, changes in parameters, software updates and trouble shooting are all possible online.



Recipe management 2

Calibration

System check

# Technical Specifications

- Mains voltage: ..... 230 V / 115 V
- Frequency: ..... 50 Hz / 60 Hz
- Power consumption: ..... 1.500 VA
- Compressed air supply: ..... 6 bar / 90 psi
- Measuring ranges: ..... 0 to 40 kg/m<sup>2</sup> / 0 to 8 lbs/ft<sup>2</sup>
- Measuring accuracy, related to the end value of the measuring range
  - with x-ray tube: ..... 0.25 % (≥ 30 g/m<sup>2</sup>)  
(≥ .006 lbs/ft<sup>2</sup>)
  - with radioactive source: ..... 0.50 % (≥ 50 g/m<sup>2</sup>)  
(≥ .011 lbs/ft<sup>2</sup>)
- X-ray tube: ..... 33 kV, 1 mA
- Radioactive source: ..... Americium 241 (300 to 500 mCi)

## References

- Particleboard
- MDF board
- HDF board
- Hardboard
- OSB board
- Mineral wool
- Insulating board
- Machined car parts



Measurement of a chip mat

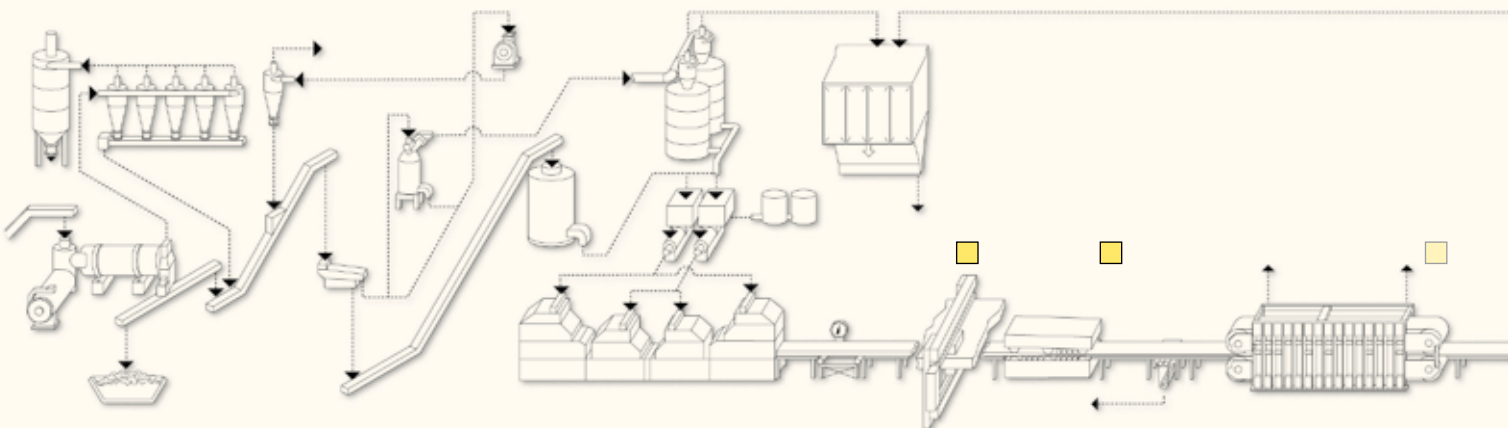

## Technical Features

- Solid aluminium frame
- Precise guidance of the measuring slides
- Protected drive
- Non-contact measurement
- 3 operation modes (cross, stationary, step)
- Variable traversing speeds
- Automatic calibration
- Windows operating system
- Recipe data base for automatic production change-over
- Long-term graphics
- Storage of the measured data in a SQL data base
- Representation of cross and longitudinal profiles
- Preparation for network connection is standard
- Telediagnostic service through GreCon after-sales service

## Applications

In particleboard and OSB board production lines, the traversing weight per unit area gauge is installed directly after the forming station; in MDF production lines it is used after the pre-press. An additional measurement of the completed panels is also possible. This is especially useful where the measurement of the material distribution prior to the press is impossible or further information is desired.

## Why GreCon



- Quick and timely recognition of quality deviations
- Clear display of the consequences of changes in the production (intentional or unintentional)
- Display of optimisation potentials
- Reliable measured values
- Flexible use with various product alternatives
- Data base for formulas, measuring data, system settings, calibration data

## Your Benefit



- Fast traverse movement - quick and strip-wise measurement of the cross profile = quick intervention in the production process possible (e. g. adjustable tables of the forming belt)
- Measurement of the longitudinal profile = detection of systematic distribution failures lengthwise/crosswise
- Safe X-ray system, operation permit is easy to obtain
- Automatic calibration = best quality of measured values
- Fast amortisation

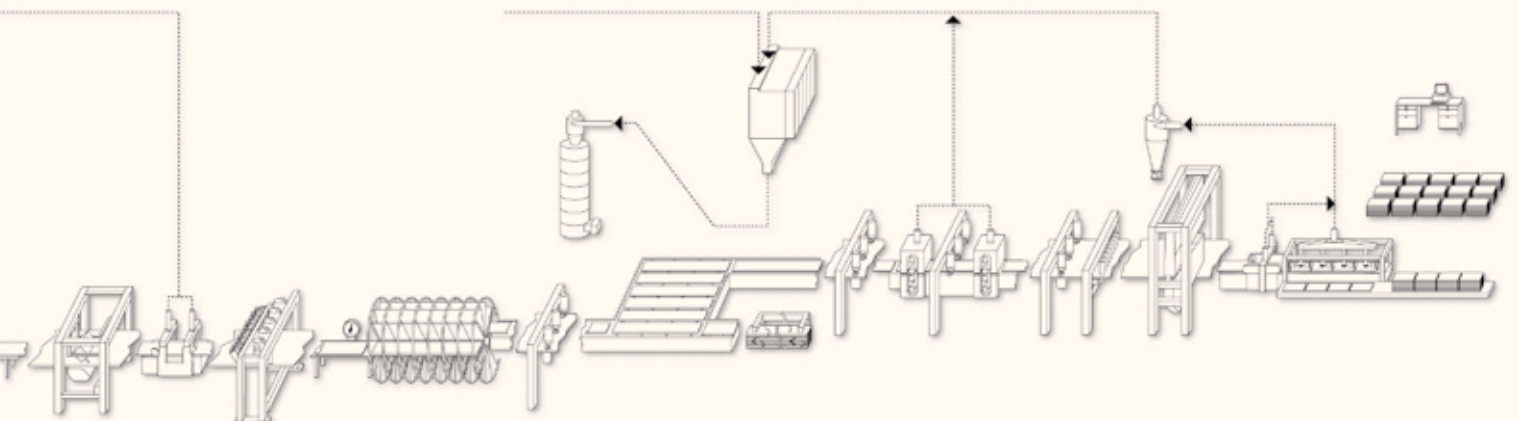



OUR HEADQUARTERS AT ALFELD - BUILT BY WALTER GROPIUS IN 1911

## GreCon

15875 SW 74th Ave.  
Tigard, Oregon 97224

TEL: (503) 641-7731  
FAX: (503) 641-7508  
E-MAIL: [sales@grecon-us.com](mailto:sales@grecon-us.com)  
WEB: [www.grecon-us.com](http://www.grecon-us.com)

